

## Gas Discharge Tubes (GDT)

## 2RT-8T2 Series

### Description

Using the technical requirements of the leading industry, RUILON has designed a super thin gas discharge tube, which is mainly used in the product's volume requirements and space constraints.

Gas discharge tubes (GDT) use noble gasses enclosed in ceramic tubes to provide an alternate circuit path for voltage spikes. The ceramic envelope and with nickel connectors allow for high loads. 2RT-8T2 Gas Discharge Tubes (GDT) series has a surge rating of 10kA/20kA, 8/20 $\mu$ s. This GDT series is perfectly suited for broadband equipment applications. The GDT's low off-state capacitance is compatible with high bandwidth applications and this capacitance loading value does not vary if the voltage across the GDT changes.



### Agency Approvals

Agency	Standards	Certificate No.
	UL1449	E508408

### Features

- I Excellent response to fast rising transients
- I Stable breakdown voltage
- I GHz working frequency
- I 8/20 $\mu$ s Impulse current capability: 10KA /20KA
- I Non-Radioactive
- I Ultra Low capacitance (<3pF)
- I Size:  $\Phi$ 8mm\*2.2mm
- I Storage and operational temperature: -40~+125°C

### Applications

- I Telecom CPE
- I Communication equipment
- I Surge Protective Devices
- I High density PCB assemblies

### Part Number Code

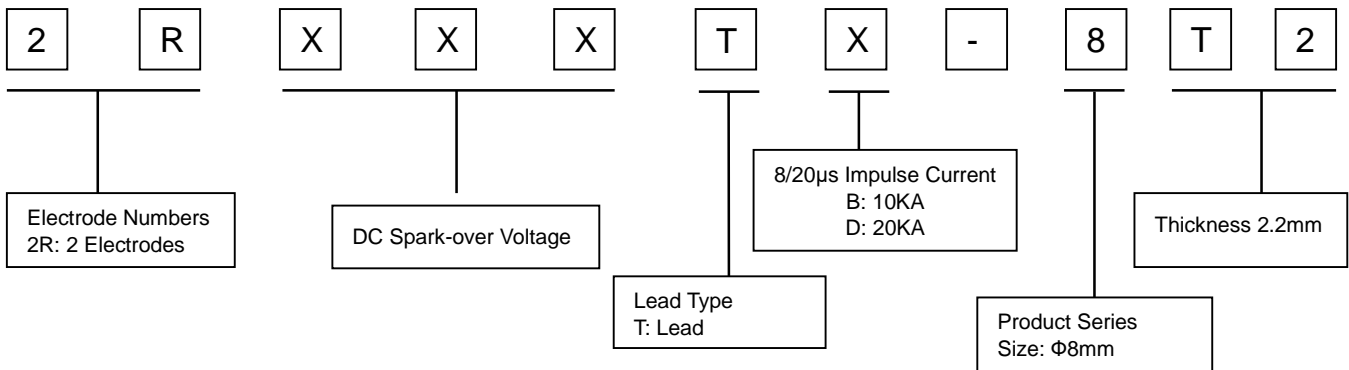

## Gas Discharge Tubes (GDT)

## 2RT-8T2 Series

### Electrical Characteristics

Part Number	DC Spark-over Voltage <sup>1) 2)</sup> @100V/S	Impulse Spark-over Voltage		Insulation Resistance <sup>3)</sup>	Capacitance @1MHz	Glow Voltage @10mA	Arc Voltage @1A	Life Ratings			
		100V/μS	1KV/μS					Impulse Discharge Current @8/20μS		Alternating Discharge Current @50Hz 1S	Impulse Life @10/1000μS
		Max	Max					±5 times	1 time	5 times	300 times
		V	V					KA	KA	A	A
2R090TB-8T2	90±20%	500	600	1	3	60	10	10	20	10	100
2R090TD-8T2	90±20%	500	600	1	3	60	10	20	25	20	100
2R150TB-8T2	150±20%	500	600	1	3	60	10	10	20	5	100
2R230TB-8T2	230±20%	600	700	1	3	135	15	10	20	5	100
2R350TB-8T2	350±20%	800	900	1	3	135	15	10	20	5	100
2R470TB-8T2	470±20%	800	900	1	3	135	15	10	20	5	100
2R600TB-8T2	600±20%	900	1000	1	3	135	15	10	20	5	100
2R800TB-8T2	800±20%	1200	1400	1	3	135	15	10	20	5	100
Glow to Arc transition Current.....					~0.5A						
Weight.....					~0.49g						
Operation and storage temperature.....					-40~+125°C						
Climatic category (IEC 60068-1).....					40/125/21						
Marking.....					without						
Surface treatment.....					Matte-tin plated						
Moisture sensitivity level <sup>4)</sup> .....					1						

<sup>1)</sup> At delivery AQL 0.65 level II, DIN ISO 2859.

<sup>2)</sup> In ionized mode.

<sup>3)</sup> Insulation Resistance Measuring Voltage:  
90V~150V at DC 50V  
Other at DC 100V

<sup>4)</sup> Tests according to JEDEC J-STD-020.

Terms in accordance with ITU-T Rec. K.12, IEC 61643-311, GB/T18802.311, GB/T 9043.

### Certifications table

Part Number	 UL1449 E508408
2R090TB-8T2	●
2R090TD-8T2	--
2R150TB-8T2	--
2R230TB-8T2	●
2R350TB-8T2	●
2R470TB-8T2	●
2R600TB-8T2	●
2R800TB-8T2	●

Notes:

1. ● indicates that the product has passed the certification.
2. -- indicates that the product is not certified.

## Gas Discharge Tubes (GDT)

## 2RT-8T2 Series

### Dimensions (Unit: mm/inch)

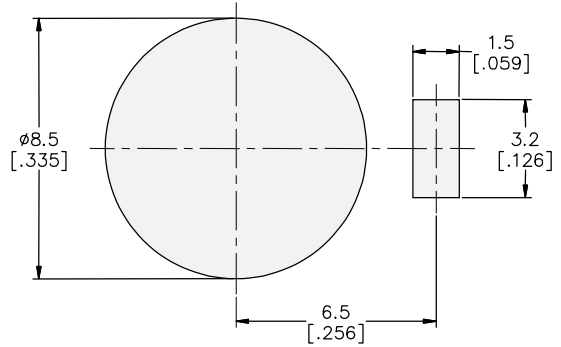
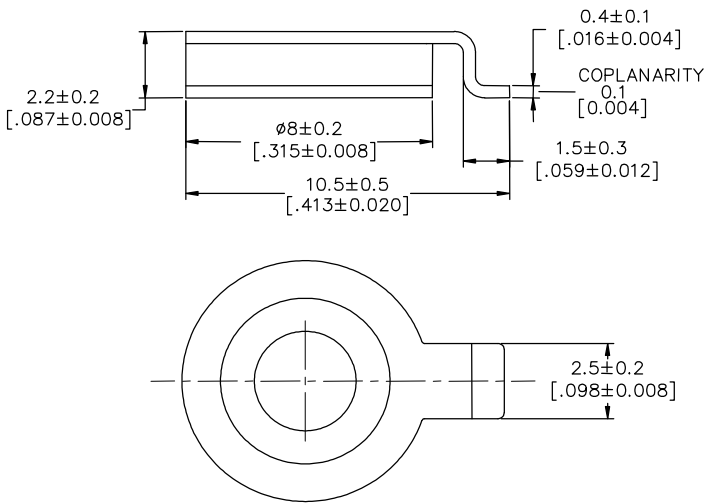

Recommended Soldering Pad Layout

### Packaging Information

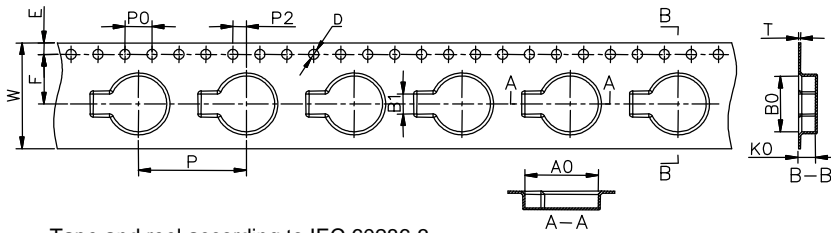

Tape and reel according to IEC 60286-3

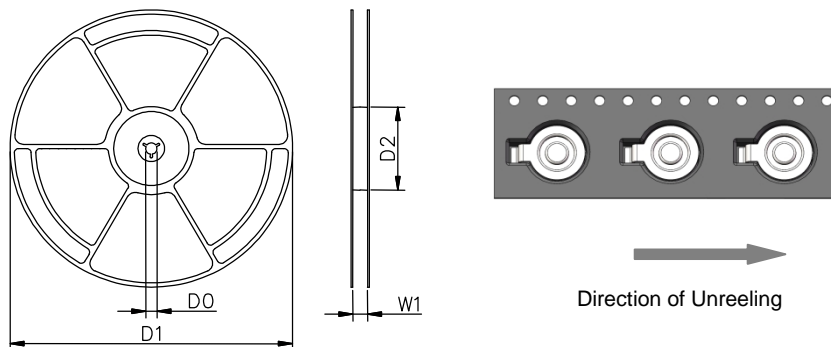

Symbol	Millimeters	Inches
<b>W</b>	16±0.3	0.630±0.012
<b>A0</b>	10.9±0.1	0.429±0.004
<b>B0</b>	8.4±0.1	0.331±0.004
<b>B1</b>	3.0±0.1	0.118±0.004
<b>K0</b>	2.5±0.1	0.098±0.004
<b>P</b>	16±0.1	0.630±0.004
<b>F</b>	7.5±0.1	0.295±0.004
<b>E</b>	1.75±0.1	0.069±0.004
<b>D</b>	1.5+0.1/-0.0	0.059+0.004/-0.0
<b>P0</b>	4±0.1	0.157±0.004
<b>P2</b>	2±0.1	0.079±0.004
<b>T</b>	0.3±0.05	0.012±0.002
<b>D0</b>	13.3±0.15	0.524±0.006
<b>D1</b>	330±2	12.992±0.079
<b>D2</b>	100+1/-2	3.937+0.039/-0.079
<b>W1</b>	16.5±0.4	0.65±0.016

### Gas Discharge Tubes (GDT)

### 2RT-8T2 Series

	Reel	Inner Box	Carton
Size	330×20.5mm	340×333×70mm	375×353×380mm
Quantity	MPQ/MOQ: 1 reel=1,500pcs	1 Inner Box=3 reels=4,500pcs	1Carton=5 Inner boxes=22,500pcs
Photos			

### Soldering Parameters - Reflow Soldering (Surface Mount Devices)

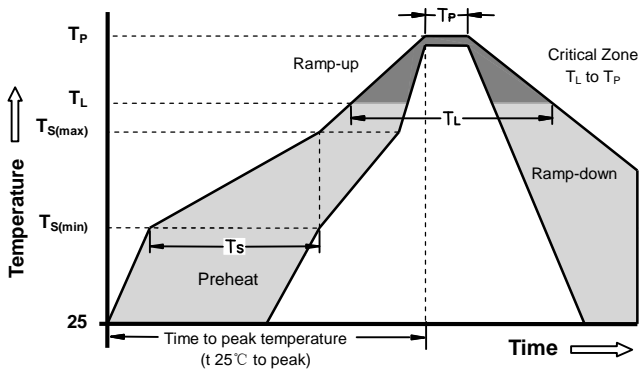

Reflow Condition		Pb - Free assembly
Pre Heat	-Temperature Min ( $T_{s(min)}$ )	150°C
	-Temperature Max ( $T_{s(max)}$ )	200°C
	- Time (min to max) ( $t_s$ )	60 - 180 Seconds
Average ramp up rate ( Liquids Temp $T_L$ ) to peak		3°C/second max
$T_{s(max)}$ to $T_L$ - Ramp-up Rate		5°C/second max
Reflow	- Temperature ( $T_L$ ) (Liquids)	217°C
	- Time (min to max) ( $t_s$ )	60 - 150 Seconds
Peak Temperature ( $T_P$ )		260 +0/-5°C
Time within 5°C of actual peak Temperature ( $t_p$ )		10 - 30 Seconds
Ramp-down Rate		6°C/second max
Time 25°C to peak Temperature ( $T_P$ )		8 minutes Max
Do not exceed		260°C

Surface mounted components (SMD) may exhibit a temporary increase in the DC spark-over voltage after the solder reflow process. The components will recover within 24 hours. There is no quality defect nor change in protection levels during the temporary change in DC spark-over voltage.

### Terms and definitions

NO.	Item	Definitions
1	<b>Gas discharge tube(GDT)</b>	A gap, or several gaps, in an enclosed discharge medium, other than air at atmospheric pressure, designed to protect apparatus or personnel, or both, from high transient voltages. Also referred to as "gas tube surge arrester".
2	<b>DC Spark-over Voltage</b>	The voltage at which the gas discharge tube sparks over with slowly increasing d.c. voltage.
3	<b>Impulse Spark-over Voltage</b>	The highest voltage which appears across the terminals of a gas discharge tube in the period between the application of an impulse of given wave-shape and the time when current begins to flow.
5	<b>Arc voltage</b>	Voltage drop across the GDT during arc current flow.
6	<b>Glow voltage</b>	Peak value of voltage drop across the GDT when a glow current is flowing.
7	<b>Impulse discharge current 8/20µs</b>	Current impulse with a nominal virtual front time of 8 µs and a nominal time to half-value of 20 µs.
8	<b>Alternating Discharge Current</b>	The rms value of an approximately sinusoidal alternating current passing through the gas discharge tube.
9	<b>Insulation Resistance</b>	Insulation resistance shall be measured from each terminal to every other terminal of the GDT. The test is performed with DC50V when normal spark-over Voltage 70~150V, others with DC100V.
10	<b>Capacitance</b>	The capacitance shall be measured once at 1 MHz between all terminals unless otherwise specified.

### Cautions and warnings

- I Do not operate surge arresters in power supply networks, whose maximum operating voltage exceeds the minimum spark-over voltage of the surge arresters.
- I Surge arresters may become hot in the event of longer periods of current stress (burn risk). In the event of overload the connectors may fail or the component may be destroyed.
- I Surge arresters must be handled with care and must not be dropped.
- I Do not continue to use damaged surge arresters.
- I The shown SMD pad dimensions represent a safe way to mount the arrester and are a recommendation of the manufacturer. During the reflow process it must be assured that no solder material reduces the insulation distance between the pads below the arrester.
- I SMD surge arresters should be soldered within 24 month after shipment.